



ARTMAN
DELTA

A passion for accuracy and detail

Kentron V3B Kukri IR Air-to-Air Missile and Launch Rail

Building Instructions and Colour Callouts

Colour Callouts:

Launch Rail

Humbrol - 126

Tamiya - XF-20

Mr. Color - C306

Vallejo - 70,870

V3B Kukri Missile

Humbrol - 80% 71 + 20% 126

Tamiya -

Mr. Color - 80% C45 + 20% C306

Vallejo - 80% 70.976 + 20% 70,870

Remove the print supports on the other side of the red lines

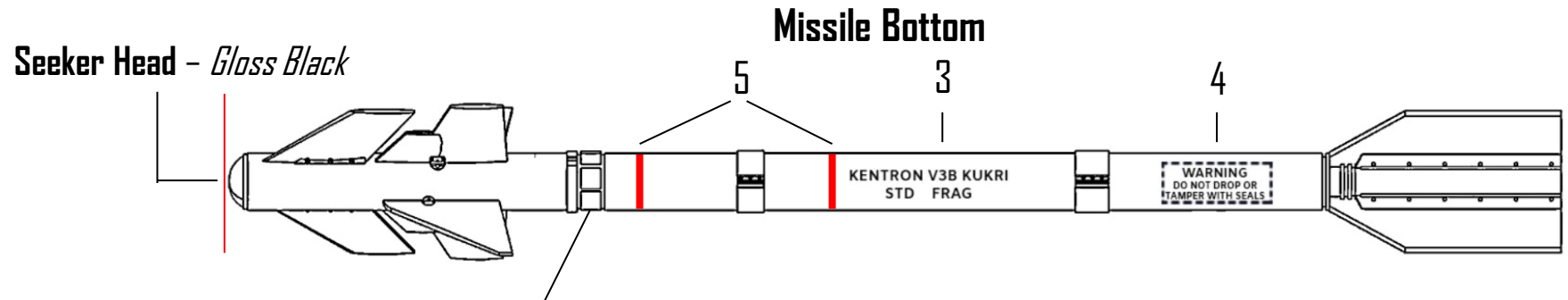

Missile Proximity Fuze - *Gunmetal Grey with Silver Panel Line Wash*

Launch Rail Top



Top Left

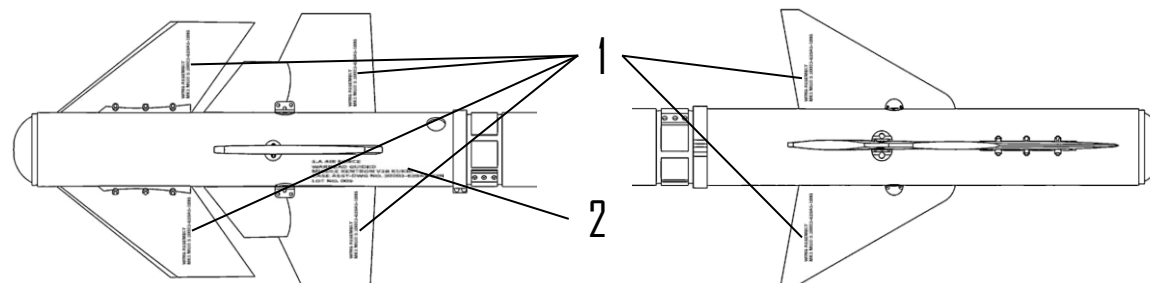

For in depth research, information and photos, see the **ArtMan Delta** Info Pack for the Kentron V3B Kukri IR Air-to-Air Missile and Launcher on the **ArtMan Delta Facebook Page**





AD32003 – Designed to be used on: 1:32 Dassault Mirage IIICZ/DZ/D2Z/EZ/RZ/R2Z and Atlas Cheetah B/C/D/E/R

1:32 Dassault Mirage FIAZ/CZ

AD48003 – Designed to be used on: 1:48 Dassault Mirage IIICZ/DZ/D2Z/EZ/RZ/R2Z and Atlas Cheetah B/C/D/E/R

1:48 Dassault Mirage FIAZ/CZ

1:48 Aermacchi MB-326K Impala Mk2

Use cyanoacrylate glue
to bond the parts
together

*It is recommended to use a
primer prior to painting the
parts

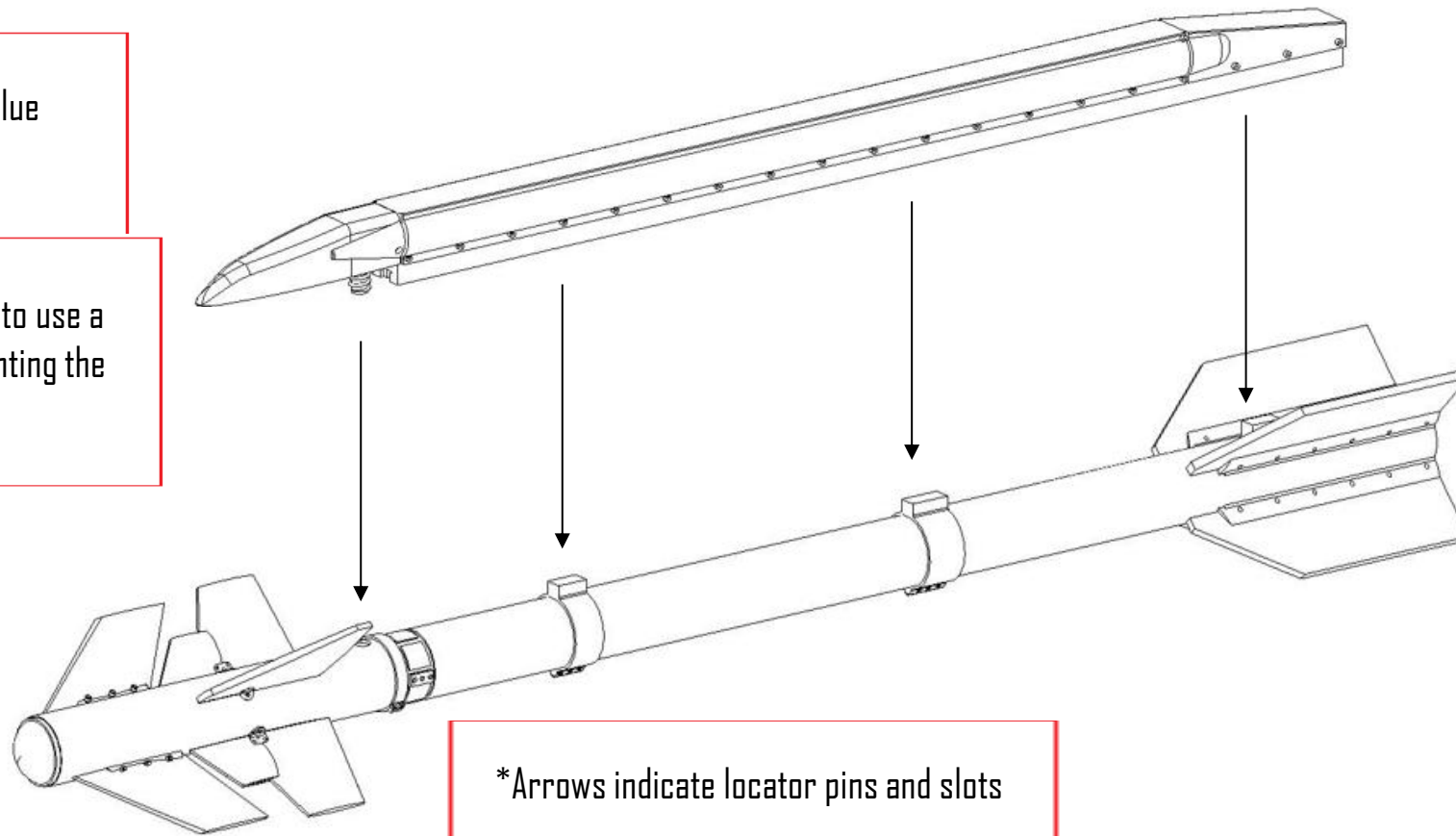

*Arrows indicate locator pins and slots

WARNING

- This is not a toy.
- These items are not suitable for children.
- Modelling experience is required.
- Always wear eye protection when cutting the resin off any supports.
- Do not breathe the resin dust in as it may be harmful to your health.
- It is recommended to wear breathing protection such as a face mask when handling and cutting/ grinding/ sanding resin.
- Not for consumption, keep away from children and animals.



ARTMAN
DELTA

A passion for accuracy and detail

RP18R 110 Gallon Supersonic Underwing Fuel Tanks

Building Instructions and Colour Callouts

Colour Callouts:

***See preferred references to decide what colours to use on your RP18R and Pylon**

For in depth research, information and photos, see the **ArtMan Delta** Info Pack for the RP18R 110 Gallon Supersonic Underwing Fuel Tanks on the **ArtMan Delta Facebook Page**

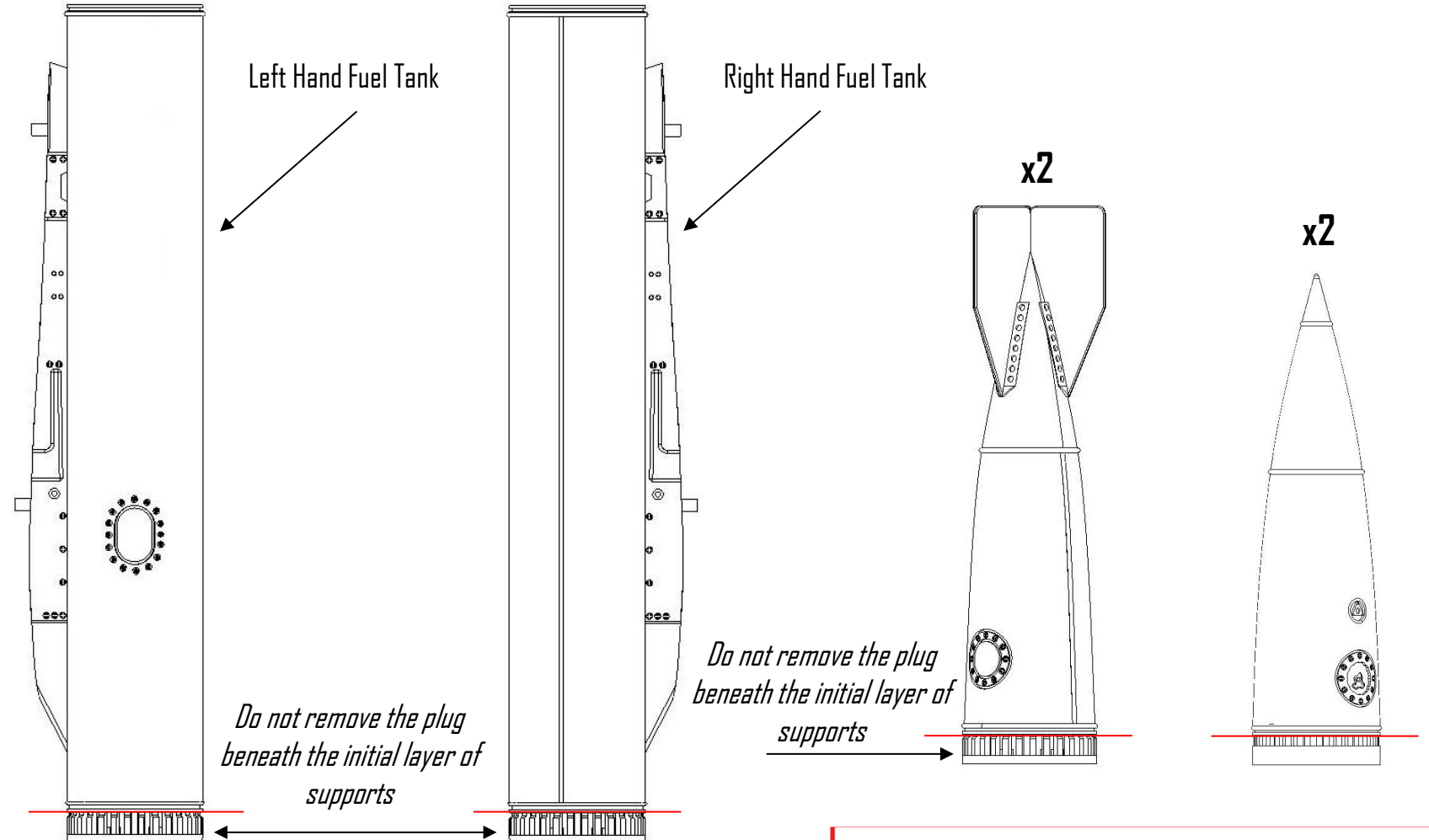

Remove the print supports below the red lines



- AD32007** - Designed to be used on Italeri 1:32 Dassault Mirage IIIC and IIIE/R and reboxed Revell 1:32 Dassault Mirage IIIE/RD/D Kits
AD48007E - Designed to be used on Eduard 1:48 Dassault Mirage IIIC and IIICJ Kits
AD48007K - Designed to be used on Kinetic 1:48 Dassault Mirage III Kits / Neshar Kits / IAI Kfir Kits and Atlas Cheetah Kits

Use cyanoacrylate glue
to bond the parts
together

*It is recommended to use a
primer prior to painting the
parts

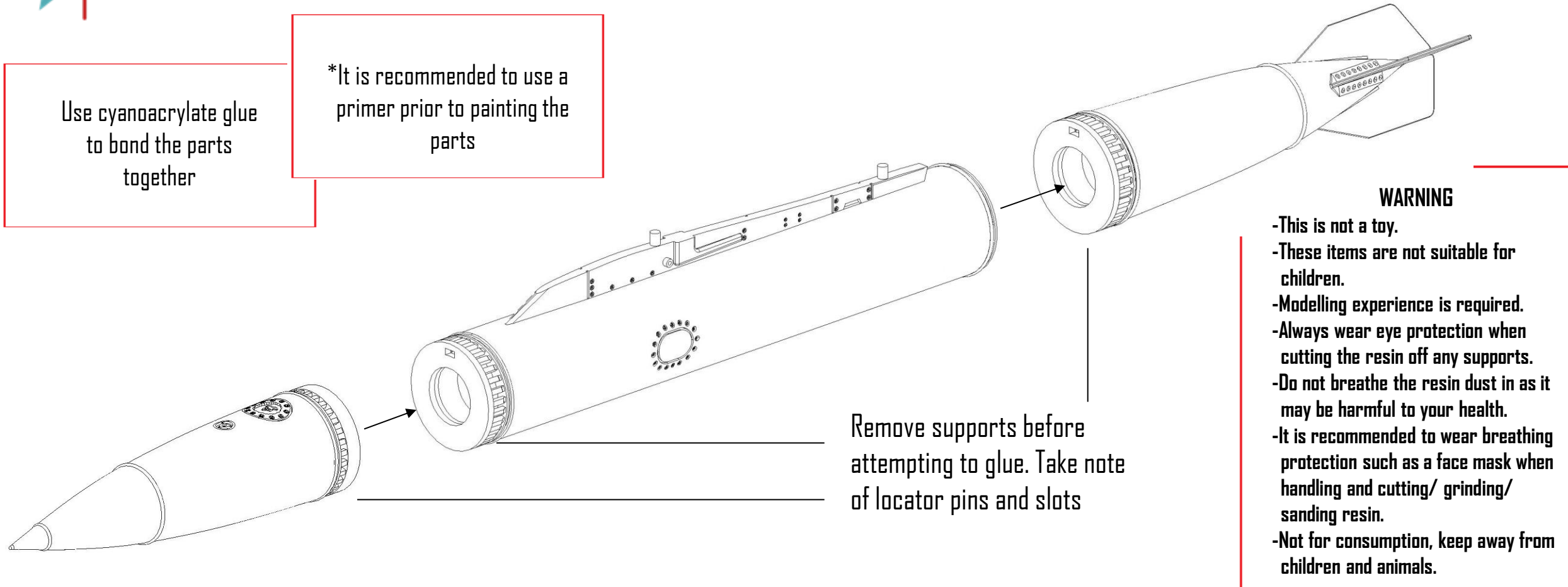

Remove supports before
attempting to glue. Take note
of locator pins and slots

WARNING

- This is not a toy.
- These items are not suitable for children.
- Modelling experience is required.
- Always wear eye protection when cutting the resin off any supports.
- Do not breathe the resin dust in as it may be harmful to your health.
- It is recommended to wear breathing protection such as a face mask when handling and cutting/ grinding/ sanding resin.
- Not for consumption, keep away from children and animals.



ARTMAN
DELTA

A passion for accuracy and detail

RP825 Supersonic Centreline Fuel Tank (Early Pylon)

Building Instructions and Colour Callouts

Colour Callouts:
***See preferred references to decide what colours to use on your RP825 and Pylon**

For in depth research, information and photos, see the **ArtMan Delta Info Pack** for the RP825 Supersonic Centreline Fuel Tan

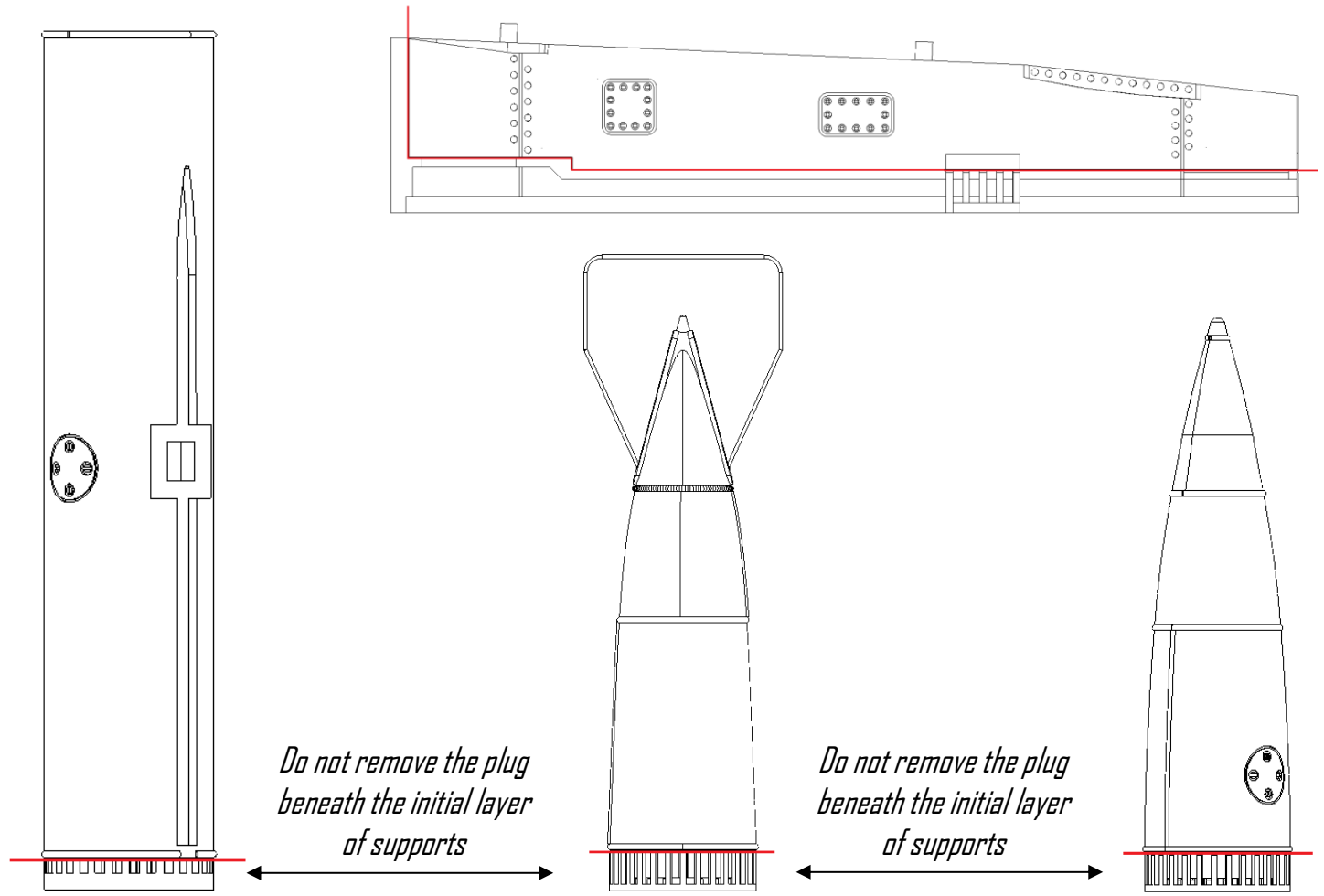

Remove the print supports below the red lines



AD32002 – Designed to be used on Italeri 1:32 Dassault Mirage IIIC and IIIE/R and reboxed Revell 1:32 Dassault Mirage IIIE/RD/O Kits
AD48002 – Designed to be used on: Eduard 1:48 Dassault Mirage IIIC and IIICJ Kits
Kinetic 1:48 Dassault Mirage III/V Kits / Nesher Kits / IAI Kfir Kits and Atlas Cheetah Kits

Use cyanoacrylate glue
to bond the parts
together

*It is recommended to use a
primer prior to painting the
parts

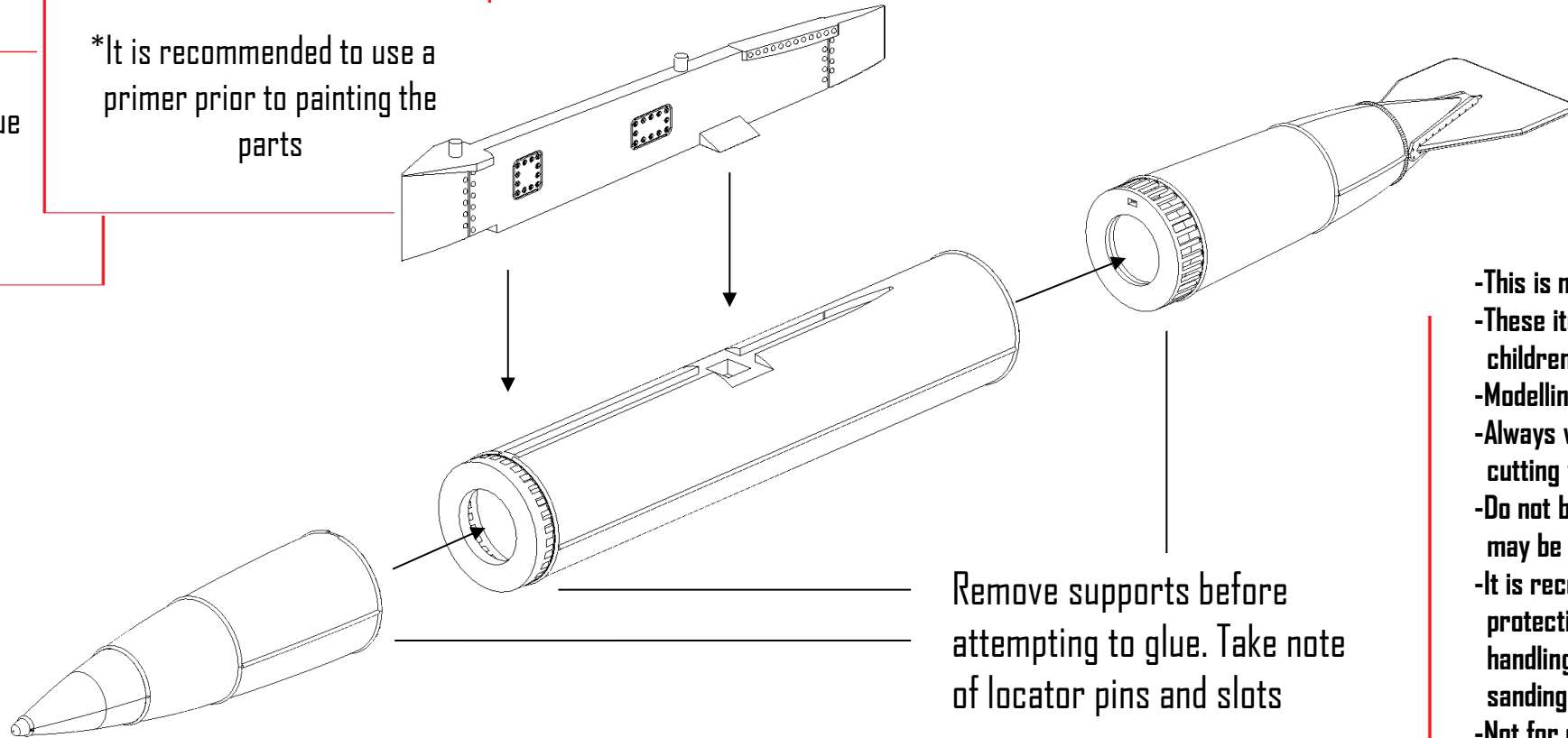

Remove supports before
attempting to glue. Take note
of locator pins and slots

WARNING

- This is not a toy.
- These items are not suitable for children.
- Modelling experience is required.
- Always wear eye protection when cutting the resin off any supports.
- Do not breathe the resin dust in as it may be harmful to your health.
- It is recommended to wear breathing protection such as a face mask when handling and cutting/ grinding/ sanding resin.
- Not for consumption, keep away from children and animals.



artmandeltasales@gmail.com



artman.delta



ArtMan Delta

Designed and Manufactured
in South Africa
© Copyright 2024