



ARTMAN
DELTA

A passion for accuracy and detail

Information Pack:

RP18R

110 Gallon Supersonic Underwing Fuel Tanks

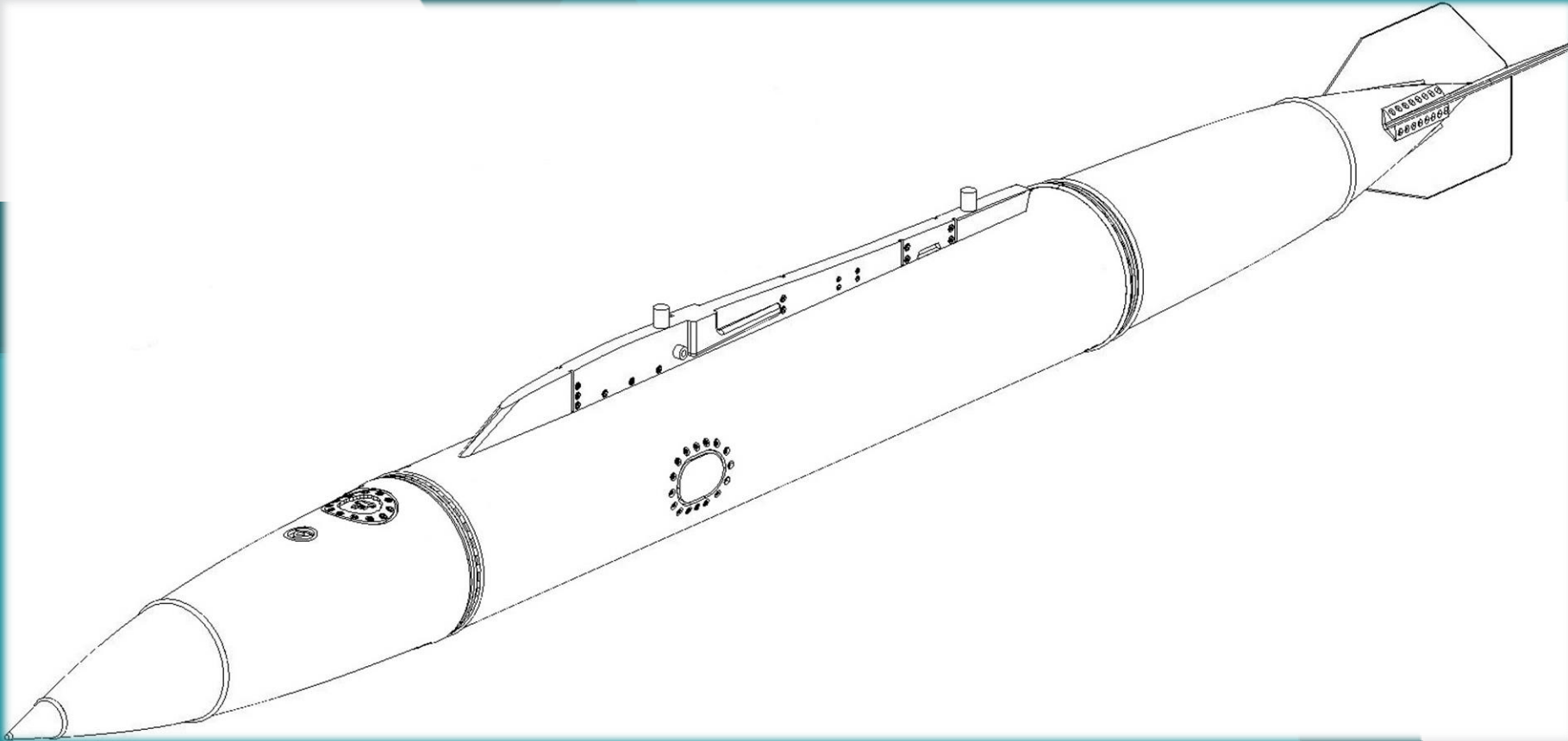



ARTMAN DELTA

A passion for accuracy and detail

RP18R

110 Gallon Supersonic Underwing Fuel Tanks

Users:

South African Air Force
Argentine Air Force
Israeli Air Force
Ecuadorian Air Force
Belgian Air Force
Australian Air Force
Pakistan Air Force
Chilian Air Force
ATAC

Aircraft Types:

Dassault Mirage
IIIB/C/D/E/RZ/R2Z/DS/S
Dassault Mirage V/Nesher/Dagger
Dassault Mirage 50
IAI Kfir C1/C2/C7/TC2
Atlas Cheetah C/D/E
ENAER Mirage 50CN Pantera

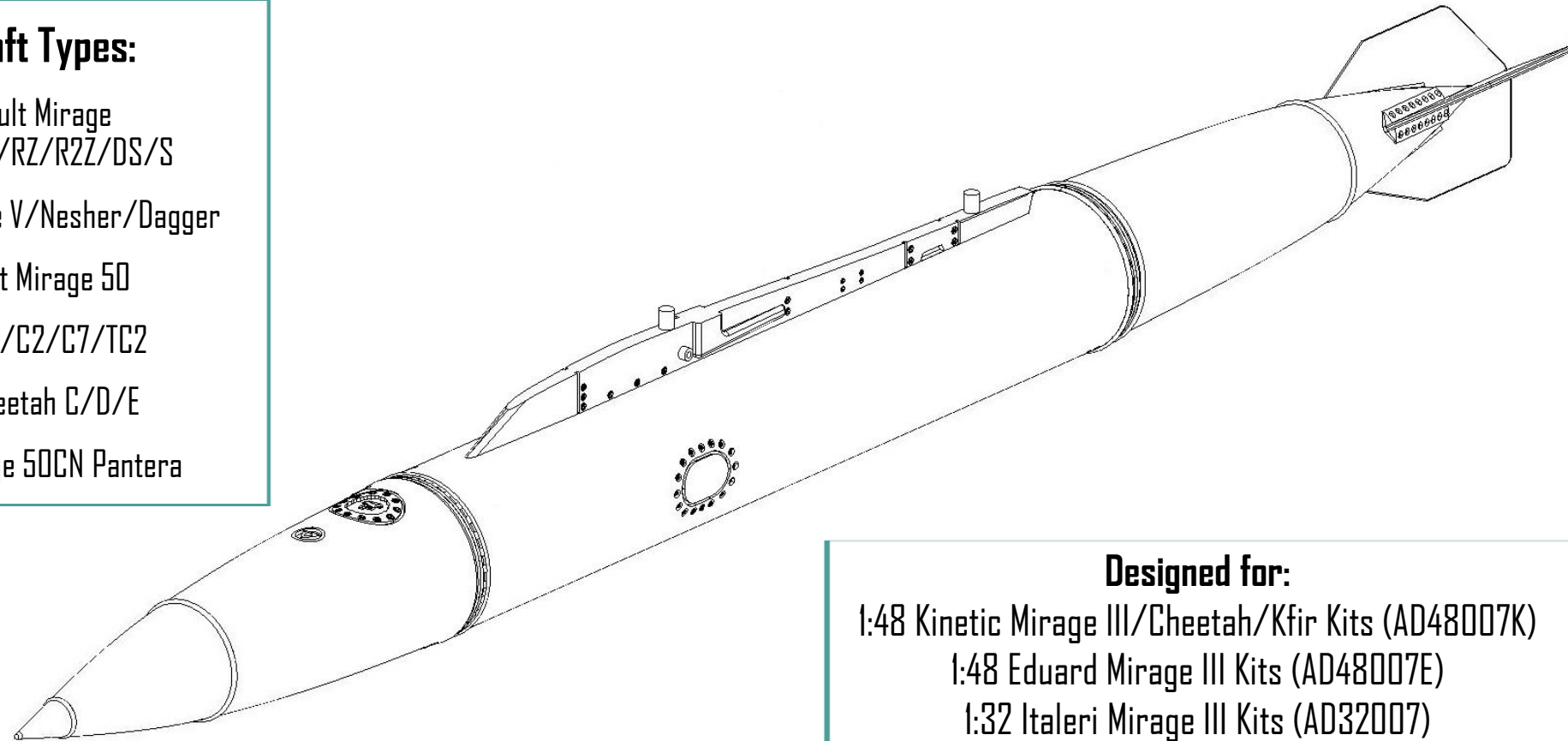

Designed for:

1:48 Kinetic Mirage III/Cheetah/Kfir Kits (AD48007K)
1:48 Eduard Mirage III Kits (AD48007E)
1:32 Italeri Mirage III Kits (AD32007)

RP18R Supersonic Underwing Fuel Tank Tech and Gen

The RP18R/IMI500 Supersonic wing Fuel Tank originated in Israel, it has a fuel capacity of 500 Litres / 110Gallons. These could be carried on the inner wing pylon of Dassault Mirage III /V/50/Kfir/F21/Pantera and Cheetah variants. It is interesting to note that there are three versions of the supersonic under wing 500Litre/110 Gallon tanks, the original French design which has no fins and which can be removed on the ground but cannot be jettisoned in flight, then there are two Israeli versions that have fins and which are jettisonable in flight. The first Israeli version is slightly longer than the French version to accommodate the internal bomb release mechanism for two 500Lb bombs and the other is identical but minus the weapon system.

The RP18R/IMI 500 was used in combat on South African Mirage III CZ, RZ and RZZ, the Israeli Air Force used them in combat on Mirage IIIBJ/IIICJ/Shahak/Nesher/Kfir C1/C2 and C7's throughout their operational lives.



Right: An RP18R mounted on a South African Air Force Dassault Mirage IIICZ



ARTMAN
DELTA

A passion for accuracy and detail

Operational History and Users

South African Air Force

2 Squadron "Flying Cheetahs" Dassault Mirage IIICZ circa 1990 suitably stationed at Air Force Base Hoedspruit near the famous Kruger National Park. This is one of the standard SAAF Mirage III configurations consisting of 1 x RP825 on the belly and a pair of VRP18R's on the inner wing stations.





ARTMAN DELTA

A passion for accuracy and detail

Operational History and Users

South African Air Force

South African Dassault Mirage IIIBZ of 2 Squadron SAAF, wearing the 1990s version of the "Castle" national insignia with an eagle in it on the air intake. It carries a pair of RP18R drop tanks on the inner wing stations. Note that this particular aircraft wears a non standard "light sand" base colour and the RP18Rs are also unusual to be camouflaged normally being in the underside colour or natural metal. Photo credit: Airliners.net





ARTMAN
DELTA

A passion for accuracy and detail

Operational History and Users

South African Air Force



A very glossy South African Mirage IIIIEZ with RPI8R and brightly coloured AAM launch rail.



Another glossy South African Mirage, this time a IIIDZZ of 85 Air Combat School carrying a pair of RPI8R's on each inner wing station. Note the yellow/orange colour on the tank, this was a protective coat.



ARTMAN
DELTA

A passion for accuracy and detail

Operational History and Users

South African Air Force

A close-up look at the protective layer which was later sprayed onto the SAAF's natural metal drop tanks, in this case an RP18R.





ARTMAN
DELTA

A passion for accuracy and detail

Operational History and Users

South African Air Force

A beautiful photograph from 1990 of a colorful South African Dassault Mirage III RZ no 838 with RP825 and a pair of RP18Rs taxiing at its base in Hoedspruit in Northeastern South Africa close to the world-renowned Kruger National Park.

Photo credit: Cloud 9 Photography.US





ARTMAN
DELTA

A passion for accuracy and detail

Operational History and Users

South African Air Force

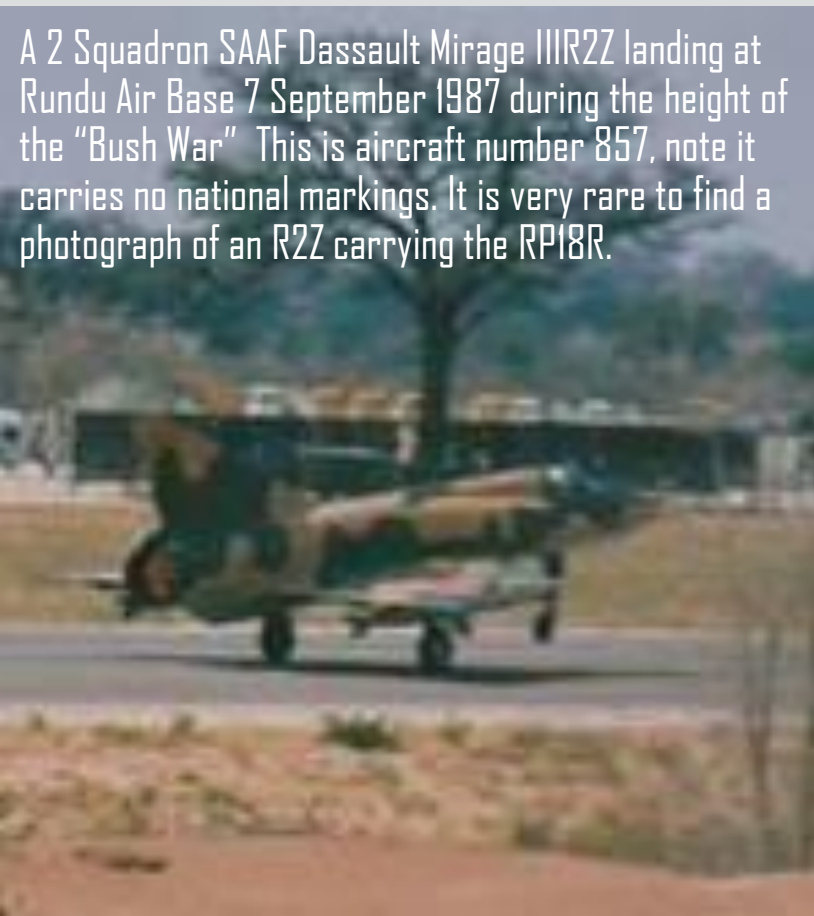

A 2 Squadron SAAF Dassault Mirage III R22 landing at Rundu Air Base 7 September 1987 during the height of the "Bush War" This is aircraft number 857, note it carries no national markings. It is very rare to find a photograph of an R22 carrying the RP18R.



A SAAF Atlas Cheetah D carrying the RP18R's and a pair of V3B Kukri short range Infrared AAM's.



ARTMAN
DELTA

A passion for accuracy and detail

Operational History and Users

South African Air Force

2 Squadron SAAF Atlas Cheetah C carrying a pair of RP18R under the wings and a RP825 supersonic centerline tank. Note that this particular RP825 has not been left in its natural metal but has instead been painted a pale grey and has teeth painted on it!



© ipmssa.za.org
A. Sandenbergh



ARTMAN
DELTA

A passion for accuracy and detail

Operational History and Users

Argentinian Air Force



Argentine Air Force Dassault Mirage IIIcJ with a pair of RP18R Fuel Tanks. Argentina received ex Israeli Mirage III "Shahak,s" after the Falklands/Malvinas war.



Argentine IAI Dagger carrying RP18R post Falklands/Malvinas war.



ARTMAN
DELTA

A passion for accuracy and detail

Operational History and Users

Argentinian Air Force

Argentine Air Force Mirage 5P Mara carrying RP18R's. This example is one of ten Peruvian Air Force 5P Maras transferred to Argentina during the Falklands/Malvinas war in 1982.



Argentine Air Force IAI Dagger carrying RP18R's.





ARTMAN
DELTA

A passion for accuracy and detail

Operational History and Users

Argentinian Air Force



Argentine IAI Dagger carrying a pair of RP18R's. This aircraft was recently restored to its Falkland/Malvinas war color scheme.



Argentine Mirage III EA carrying a pair of RP18Rs.



ARTMAN
DELTA

A passion for accuracy and detail

Operational History and Users

Israeli Air Force



A beautiful study of an Israeli Air Force Mirage III in the delivery natural metal finish carrying R530's, IAF Mirage III's flew combat missions recording a number of Air-to-Air "kills".



ARTMAN
DELTA

A passion for accuracy and detail

Operational History and Users

Israeli Air Force



Israeli Air Force Mirage III CJ 52 in the delivery natural metal finish carrying RP18R's and a Matra 530 AAM. This particular aircraft would later go on to score 10 Air-to-Air kills during its service, the majority of which being achieved using canons.



ARTMAN
DELTA

A passion for accuracy and detail

Operational History and Users

Israeli Air Force



A mixed flight of four Israeli Air Force Dassault Mirage IIIBJ and Mirage IIIC about to take off on a training mission, note the RP18R's underwing and RP825's on the centreline pylon.



ARTMAN
DELTA

A passion for accuracy and detail

Operational History and Users

Israeli Air Force



The Israeli Air Force (IAF) Nesher is an Israeli version of the Dassault Mirage V. This aircraft carries a typical Air to Air load of an RP62 1300L fuel tank mounted on a CRP37 Centreline Pylon, a pair of RP18R's and a pair of AIM-9D 'Deker' AAM's. Note the single "kill" marking roundel under the front of the windshield. Colorization by Finkelman Shay



ARTMAN
DELTA

A passion for accuracy and detail

Operational History and Users

Israeli Air Force



Above: Israeli Air Force (IAF) Dassault Mirage III CJ "Shahak" 107 of the 'First Jet Squadron, This Shahak was fitted with the more powerful ATAR 9C replacing the original ATAR 9B engine. This aircraft carries a typical Air-to-Air Combat Air Patrol load of an RP825 tank on the centreline pylon, a pair of RP18R's and a pair of Rafael Shafir 2 AAM's. This aircraft also shows the yellow and black triangles painted during the Yom Kippur War of 1973 for Friend or Foe identification purposes. This aircraft was credited with 4 Air-to-Air kills.

Below: A very colourful IAF Neshet B of 'The Hornets' Squadron, carrying an RP825 on the centreline pylon and a pair of RP18R 500L/110Gal underwing Supersonic Fuel tanks. Neshet B's were used during combat during the Yom Kippur War with some scoring Air-to-Air kills. Neshet 666 entered service in 1974, too late to participate in the Yom Kippur War but was not one of the aircraft sold to Argentina later on, instead being used as an airframe that was converted into an IAI Kfir TC2





ARTMAN
DELTA

A passion for accuracy and detail

Operational History and Users

Israeli Air Force



Israeli IAI Kfir TC2 of the Israeli Air Force Aircraft Test Centre, with a pair of RPI8R's, a pair of Python 3 AAM's and GBU-12 500lb Laser guided bomb. The blue colouring of the AAMs and GBUs indicates that these are practice rounds.



ARTMAN
DELTA

A passion for accuracy and detail

Operational History and Users

Israeli Air Force

Israeli IAI Kfir C7 with a standard Air-to-Air load of a pair of RP18R's an RP825 on the centreline pylon and a pair of Python 3 AAM's. In this case, the Python 3's are practice rounds.





ARTMAN
DELTA

A passion for accuracy and detail

Operational History and Users

Ecuadorian Air Force

Ecuadorian Air Force Kfir CE. This aircraft carries seven 500lb Mk82 bombs, a pair of RP18R's and a pair of Rafael Python 4 AAM's



AirHistory.NET

PHOTO COPYRIGHT © SANDRO ROTA



ARTMAN
DELTA

A passion for accuracy and detail

Operational History and Users

Ecuadorian Air Force



Ecuadorian IAI Kfir C2 with RP18R's and a pair of empty Python 3 Launch Rails on the outer wing stations.



Ecuadorian Atlas Cheetah C carrying RP18R's.. Note the different style of In-Flight refuelling probe immediately behind the cockpit on this aircraft which is unique to the Atlas Cheetah C.



ARTMAN
DELTA

A passion for accuracy and detail

Operational History and Users

Belgian Air Force

Daniel Brackx
PHOTOGRAPHY



A nice shot of a Belgian Mirage 5BA carrying a pair of RP18R underwing fuel tanks for a fully supersonic configuration. Belgian Mirages only once deployed for active Combat Air patrol and Recce missions, BAF 8th Sqn received the order to deploy with 18 Mirage 5s to Diyarbakir Air Base, in the Southeast of Turkey during the first Gulf war and were tasked with to protecting Turkish air bases where coalition aircraft were launching strike and Combat Air Patrol missions from.



ARTMAN
DELTA

A passion for accuracy and detail

Operational History and Users

Belgian Air Force



A Belgian Mirage 5BD training aircraft carrying RP18R underwing and what appears to be a "luggage" pod on the centreline pylon.

Below: Belgian Mirage 5BR recce aircraft carrying RP18R.



© Photo Belgian Air Force

www.belgian-wings.com



ARTMAN
DELTA

A passion for accuracy and detail

Operational History and Users

Australian Air Force



A beautiful Australian Mirage III E0 carrying a pair of RP18R's and an RP62 1300 liter centerline tank on what appears to be a modified PM-3 Bomb pylon.



ARTMAN
DELTA

A passion for accuracy and detail

Operational History and Users

Australian Air Force



Australian Dassault Mirage III D carrying an Air-to-Air Combat Air Patrol load of a pair of RP18R's, AIM-9B's and Matra 530 missile on the centreline. Australian Mirages carried a variety of drop tanks the RP18R being among them.

Australian Dassault Mirage III D carrying a pair of RP18R's and a Matra 530 AAM on the centerline pylon.





ARTMAN
DELTA

A passion for accuracy and detail

Operational History and Users

Pakistani Air Force



Above: Pakistani Mirage 5PA2 carrying RP18R's.



Below: A smart looking Pakistani Mirage IIIE. Note the refueling probe, unique to Pakistani Mirages and RP18R's with empty AAM launch rails.



ARTMAN
DELTA

A passion for accuracy and detail

Operational History and Users

Pakistani Air Force

A colorful Pakistani Mirage IIIDP carrying RP18R's. Pakistani Mirages underwent many modifications, modernizations and upgrades throughout their service histories to retain a familiar and reliable platform. Photo Credit Awais Lali and Airliners.net



COPYRIGHT AWAIS LALI

AIRLINERS.NET



ARTMAN
DELTA

A passion for accuracy and detail

Operational History and Users

Pakistani Air Force



A spectacular looking ex-Australian Air Force Dassault Mirage III with ex-South African Air Force Mirage IIIEZ wings still in their SAAF deep buff/dark green camo carrying RP18R's.



ARTMAN
DELTA

A passion for accuracy and detail

Operational History and Users

Chilean Air Force



Chilian Air Force Mirage 5 "Elkan" that were bought from Belgium. In 1988 the Belgian Air Force decided to upgrade 20 Mirages with the Mirage System Improvement Program (MirSIP). The fall of the Berlin Wall however changed the political situation and it was decided that the improvement program was no longer justified. Chile took over the improved Mirages and incorporated Chilean specific modifications and called the aircraft "Elkan". On this example the RP18R's are an all over green colour.



ARTMAN
DELTA

A passion for accuracy and detail

Operational History and Users

Chilean Air Force



Another example of a Chilean Air Force Mirage 5 "Elkan". Note how the aircraft retained the Belgian style camouflage colours and the Elkan specific emblem on the tail.



ARTMAN
DELTA

A passion for accuracy and detail

Operational History and Users

ATAC



An unusual asymmetrical loadout on this ATAC F-21 Lion (Kfir C2).



ARTMAN
DELTA

A passion for accuracy and detail

Operational History and Users

ATAC

An ATAC operated IAI Kfir C2 with a pair of RP18R underwing tanks, an RP825 centreline tank and an SAIP Pod under the starboard wing. ATAC use their Kfir's for dissimilar air combat training and support against US Military aviation branches as tactical adversaries.





ARTMAN
DELTA

A passion for accuracy and detail

Building Instructions and Colour Callouts

Colour Callouts:

***See preferred references to decide what colours to use on your RP18R and Pylon**

***It is recommended to use a primer prior to painting the parts**



Left Hand Tank

x2

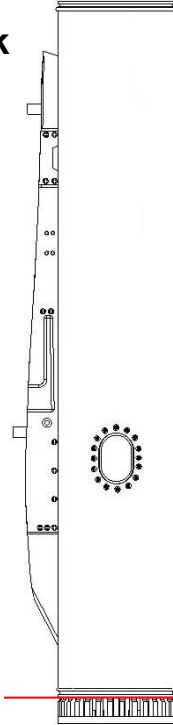

Right Hand Tank

x2



Do not remove the plug beneath the initial layer of supports

Do not remove the plug beneath the initial layer of supports

Remove the print supports below the red lines



ARTMAN
DELTA

A passion for accuracy and detail

Building Instructions and Colour Callouts

Colour Callouts:

***See preferred references to decide what colours to use on your RP18R and Pylon**

Use cyanoacrylate glue to bond the parts together

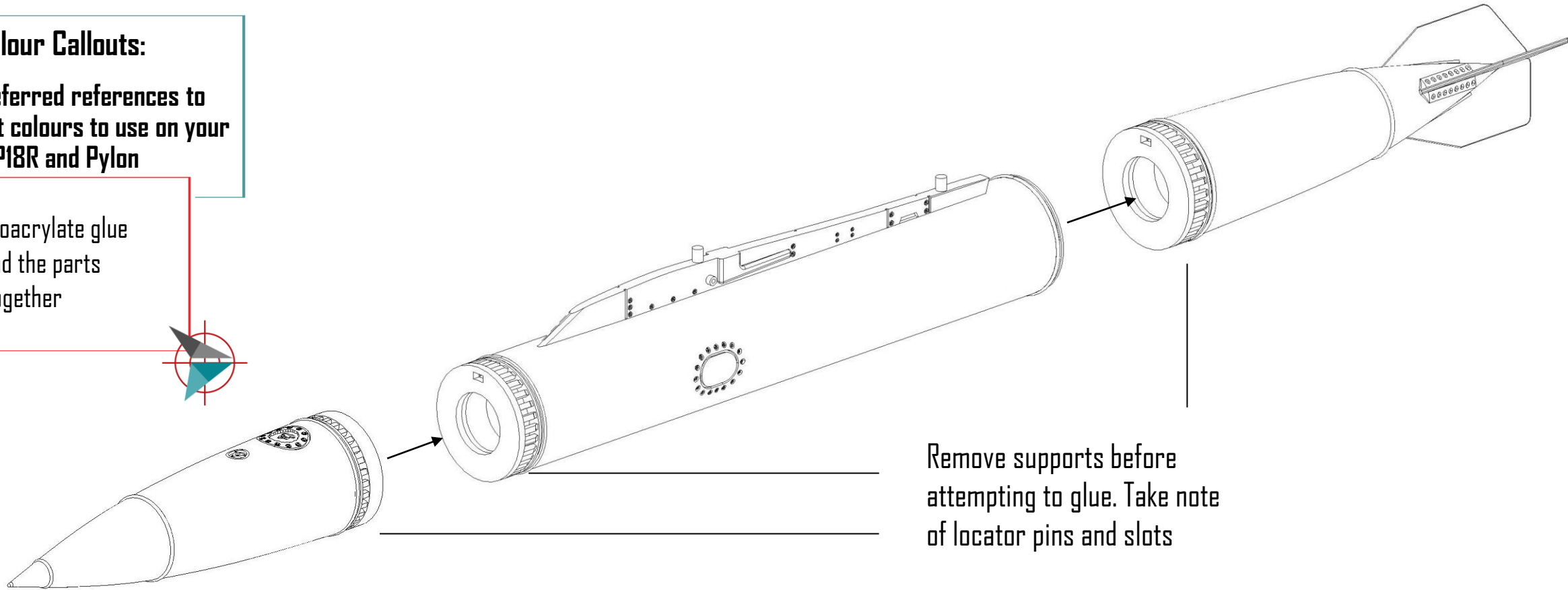

Remove supports before attempting to glue. Take note of locator pins and slots



ARTMAN
DELTA

A passion for accuracy and detail

ArtMan Delta Disclosures

WARNING

This is not a toy.

These items are not suitable for children .

Modelling experience is required.

Always wear eye protection when cutting the resin off any supports.

Do not breathe the resin dust in as it may be harmful to your health.

It is recommended to wear breathing protection such as a face mask when handling and cutting/ grinding/ sanding resin.

Not for human consumption, keep away from children.

Acknowledgements

Every effort has been made to reproduce these scale model accessories to as accurate proportions as possible from measured full scale aircraft parts and resulting technical drawings. All work is original. We would like to thank ArtMan Delta's good friends, Malcolm Reid and Daan Conraadie for their incredible insight, knowledge and information shared with ArtMan Delta to make these parts into what they are. ArtMan Delta would also like to thank any unreferenced photographers for their incredible photographs that have assisted in giving the level of detail ArtMan Delta wishes to share with the world for the benefit of historical remembrance and accurate facts but most importantly the joys of modelling. Should any of the photographers recognise photographs in these instruction sheets, please contact ArtMan Delta in order for us to give credit where credit is due. Lastly, thank you, to you, our customer for purchasing an ArtMan Delta set, without your support none of this would be possible.