



ARTMAN
DELTA

A passion for accuracy and detail

Information Pack:

Matra JL-100 Rocket Pod Fuel Tanks

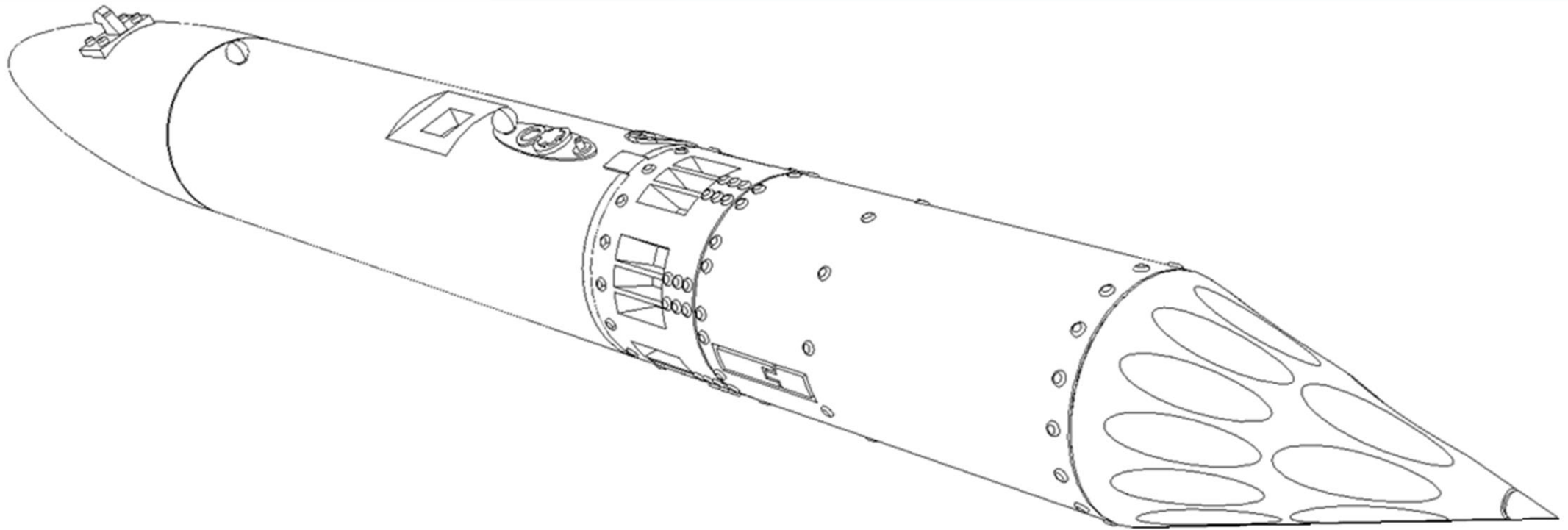



ARTMAN
DELTA

A passion for accuracy and detail

Matra JL-100

Combined Fuel Tank Rocket Pod

Aircraft Types:

Dassault Mirage III C/E/RZ/R2Z

Dassault Mirage V

Dassault Mirage 50

English Electric Lightning F.52/F.53K

Users:

South African Air Force

French Air Force

Lebanese Air Force

Royal Saudi Air Force

Peruvian Air Force

Venezuelan Air Force

Kuwait Air Force

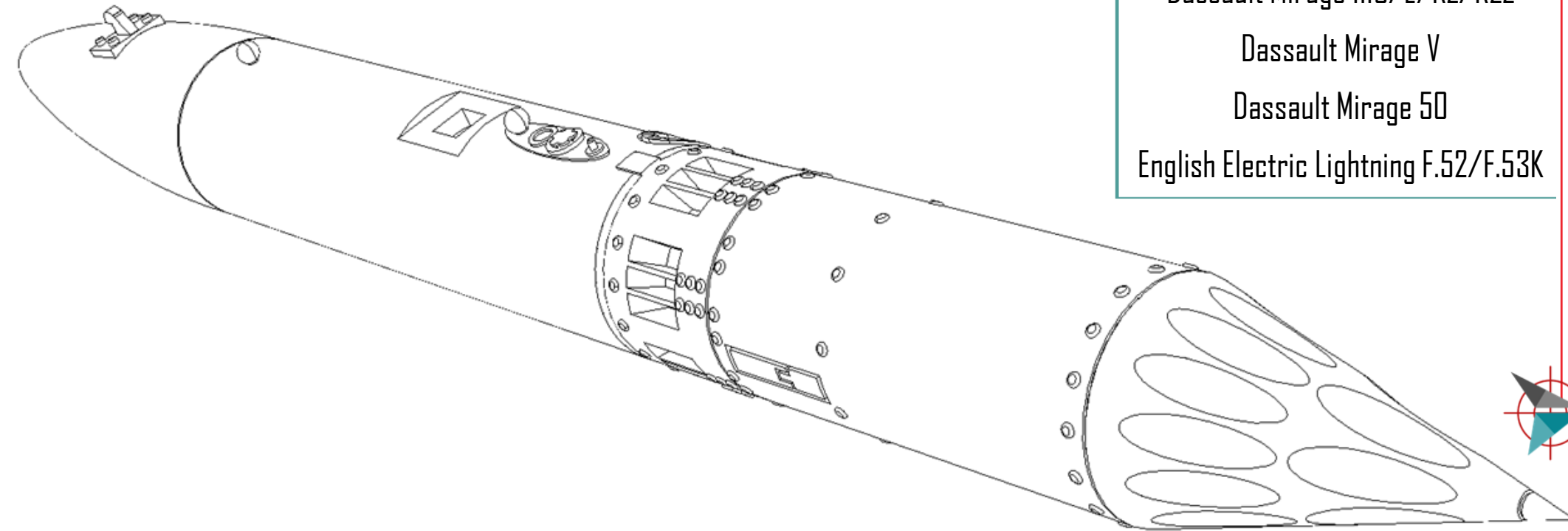



ARTMAN DELTA

A passion for accuracy and detail

Matra JL-100 Tech and Gen

The Matra JL-100 Combined Fuel Tank Rocket pod has a fuel capacity of 250 liters / 66 Gallons. The forward rocket pod accommodated 18 x 68mm SNEB folding fin aerial rockets. These could only be carried on the inboard wing pylons of Dassault Mirage III variants using CRP-18 Pylons.

The English Electric Lightning of the Royal Saudi Air Force and Kuwaiti Air Force was also able to fit JL-100's on overwing stations. Mountings were created whereby two JL-100's could be able to be carried side by side on these stations. It is unknown whether these side by side JL-100 Rocket Pods were ever trialled in the air, let alone used in combat.

The SAAF used the JL-100 in anger on a number of Operations in and around Angola during what has come to be known as The Bush War, notably during Operation Rekstok in 1979. The JL-100's were able to be carried by the SAAF's Dassault Mirage III variants.

Other Nations sporting Dassault Mirage III / V / 50 variants in their hangars, were also fitted to carry the JL-100 as it was an effective and useful weapon in the ground attack role and added that bit of extra range to the already limited Dassault Mirage fighter range.

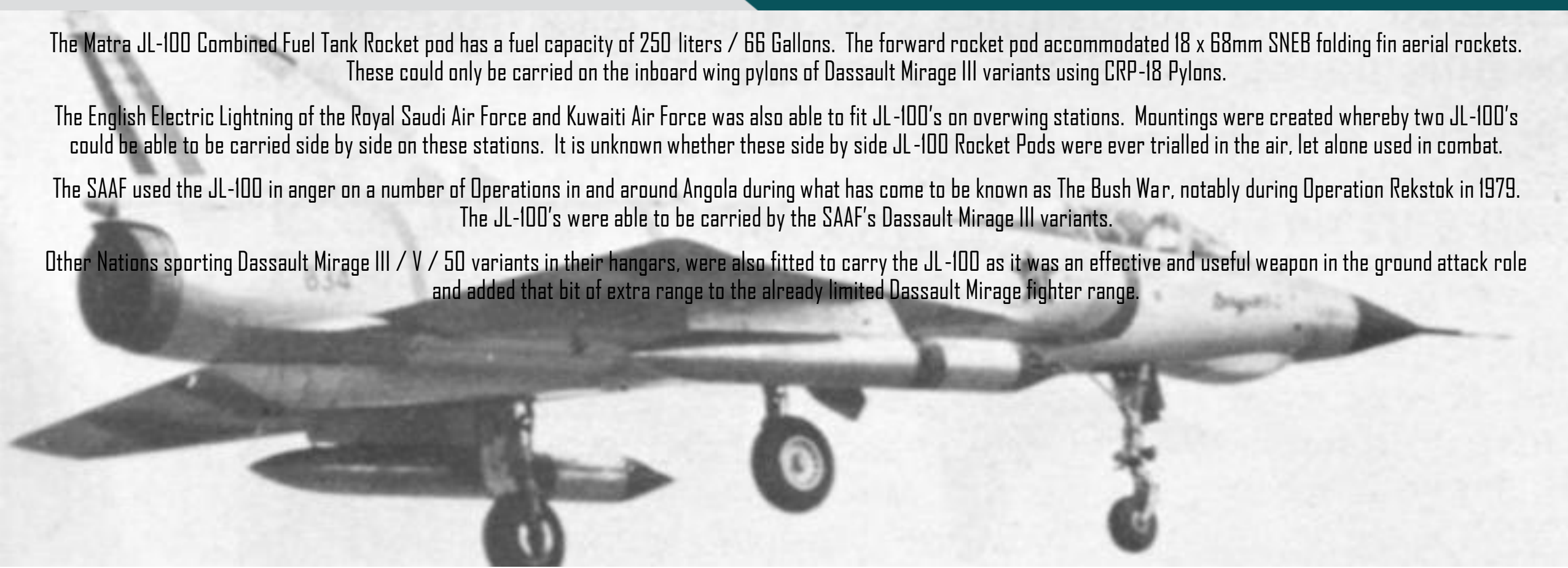



ARTMAN

DELTA

A passion for accuracy and detail

Operational History and Users

South African Air Force



Dassault Mirage IIIDZZ of 85 Air Combat/Advanced Flying School, stationed at Air Force Base Pietersburg along with Dassault Mirage IIIDZs, IIIEZs and Sabres prior to a training sortie most likely on it's way to Roodewal Weapons Range.



The ultimate selfie! A photo taken of a Dassault Mirage IIIDZZ and IIIEZ over Southern Angola in 1979 during Operation Rekstok. This was the only time the SAAF IIIEZs were used in combat. This photo shows the typical weapons load of the two IIIEZ's and two IIIDZZ's used for the Operation during that period.



ARTMAN
DELTA

A passion for accuracy and detail

Operational History and Users

South African Air Force

Left: A rare photograph of a Dassault Mirage IIIRZ fitted with J1100 Fuel Tank Rocket Pods. Note the rocket head colour not being the typical matt black, this is due to a fibreglass cover being fitted over the front of the frangible rocket covers and rocket head.



Another rare photograph, this time of a Dassault Mirage IIIR2Z of the SAAF. SAAF Reconnaissance aircraft did not typically carry Air-to-Ground Weaponry.





ARTMAN
DELTA

A passion for accuracy and detail

Operational History and Users

French Air Force

Rare photographs of a French Air Force Dassault Mirage IIIC 10-SN carrying an asymmetrical load of single JL-100 Rocket Pod Fuel Tank, 700L Fuel Tank and PM-3 Centreline Bomb Pylon loaded with Practice Bombs and Dispenser.

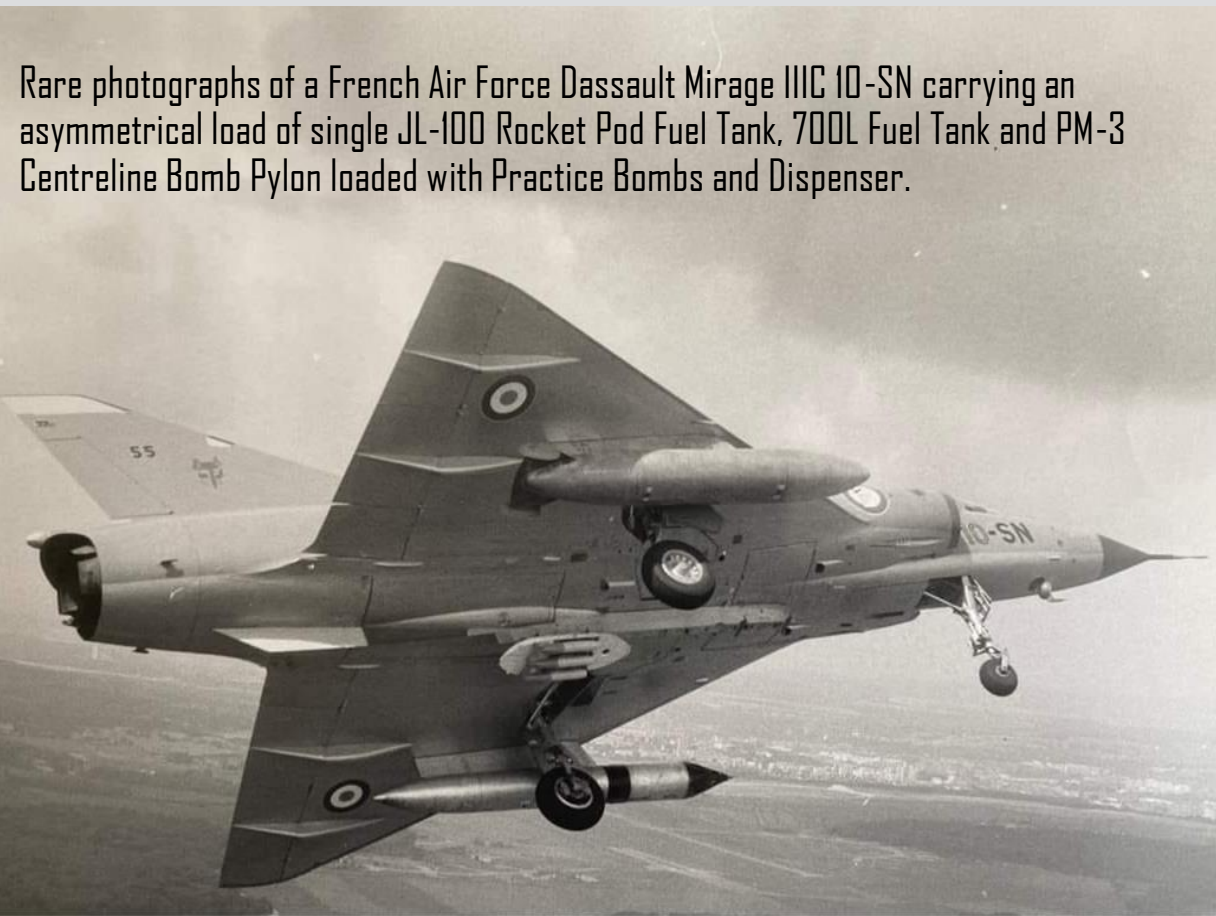



ARTMAN
DELTA

A passion for accuracy and detail

Operational History and Users

French Air Force

A beautiful study of a French Air Force Dassault Mirage 5F with a pair of JL-100 Rocket Pod Fuel Tank's and PM-3 Centreline Bomb Pylon loaded with Bombs. Interesting to note here are the fuel tank sections of the JL-100 being painted in Green.





ARTMAN
DELTA

A passion for accuracy and detail

Operational History and Users

Peruvian Air Force



Colección Sergio de la Puente

A colourful Peruvian Air Force Dassault Mirage 5 displaying the delivery colour scheme and a pair of JL100s



An unusual photograph of a Peruvian Air Force Dassault Mirage 5/50 displaying a painted JL100. JL100's were not typically painted.



ARTMAN

DELTA

A passion for accuracy and detail

Operational History and Users

Venezuelan Air Force

A Venezuelan Air Force Dassault Mirage 5V showing it's vast array of weaponry cleared for combat. Note the JL-100 in the foreground of the photograph. Also interesting to see is the Aerospatiale Exocet Anti-ship Missile on the centre pylon of the aircraft which shows its combat capabilities.





ARTMAN

DELTA

A passion for accuracy and detail

Operational History and Users

Lebanese and Kuwaiti Air Forces



Lebanese Air Force Dassault Mirage IIIEL circa 1969. 10 Lebanese Mirage IIIEL's were delivered between 1967 and 1969. Shortly after the Mirages were delivered to Lebanon they became the focus in a scandal whereby an ex-Lebanese Air Force Officer plotted to steal an aircraft to hand over to the Soviets for evaluation.



Kuwaiti Air Force English Electric Lightning F.53K circa 1969. Note the overwing mounted JL-100's and larger array of weaponry able to be carried compared to RAF Lightnings. It is important to note that it is believed that Lightnings only carried Dual JL100's on the overwing stations in concept only.



ARTMAN
DELTA

A passion for accuracy and detail

Building Instructions and Colour Callouts

Colour Callouts:

A - Rocket Nose and Centre Blast Sections

Humbrol - 85
Tamiya - X-18
Mr. Color - C33
Vallejo - 70.950

B - Rocket Body Section

Humbrol - 191 / 27002
Tamiya - TS-83
Mr. Color - C8
Vallejo Metal Color - 77.716

C - Fuel Tank Section

Humbrol - 56 / 27001
Tamiya - AS-12
Mr. Color - C8
Vallejo Metal Color - 77.717

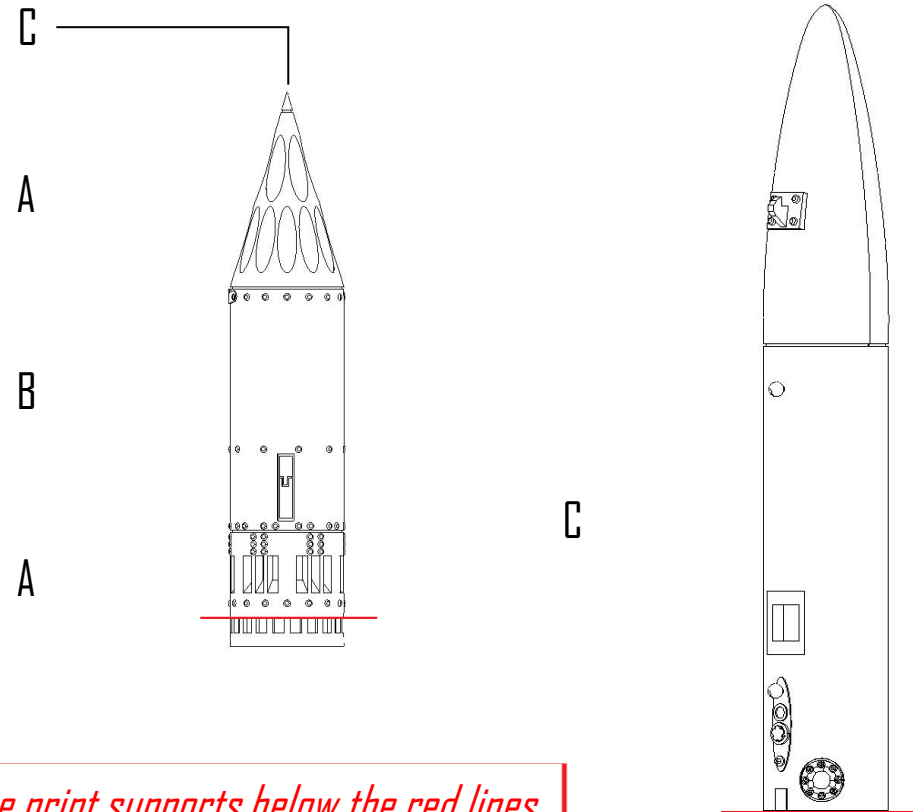

Remove the print supports below the red lines

*It is recommended to use a primer prior to painting the parts





ARTMAN DELTA

A passion for accuracy and detail

Building Instructions and Colour Callouts

Colour Callouts:

A - Rocket Nose and Centre Blast Sections

- Humbrol - 85
- Tamiya - X-18
- Mr. Color - C33
- Vallejo - 70.950

B - Rocket Body Section

- Humbrol - 191 / 27002
- Tamiya - TS-83
- Mr. Color - C8
- Vallejo Metal Color - 77.716

C - Fuel Tank Section

- Humbrol - 56 / 27001
- Tamiya - AS-12
- Mr. Color - C8
- Vallejo Metal Color - 77.717

Note the locator pin slot for correct orientation

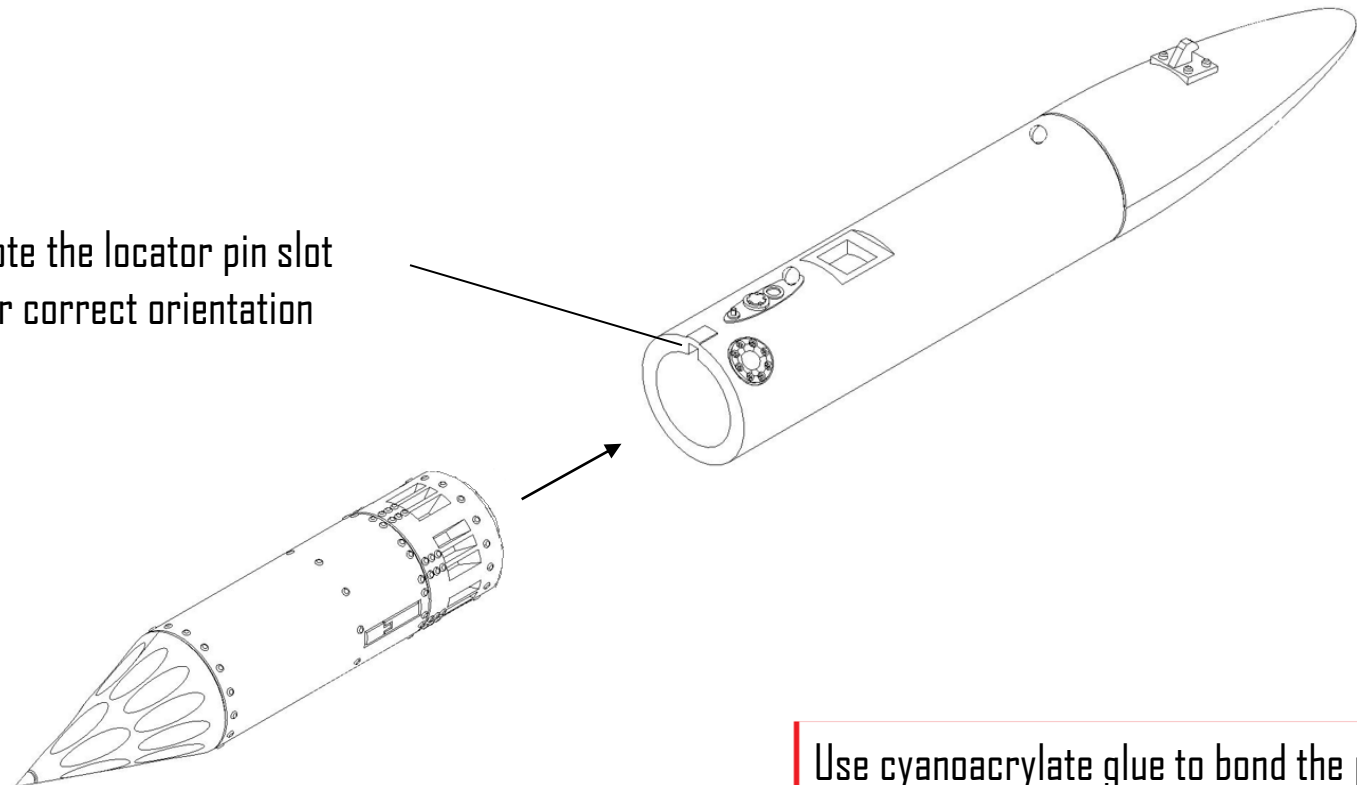

Use cyanoacrylate glue to bond the parts together



WARNING

This is not a toy.

These items are not suitable for children .

Modelling experience is required.

Always wear eye protection when cutting the resin off any supports.

Do not breathe the resin dust in as it may be harmful to your health.

It is recommended to wear breathing protection such as a face mask when handling and cutting/ grinding/ sanding resin.

Not for human consumption, keep away from children.

Acknowledgements

Every effort has been made to reproduce these scale model accessories to as accurate proportions as possible from measured full scale aircraft parts and resulting technical drawings. All work is original. We would like to thank ArtMan Delta's good friend, Malcolm Reid for his incredible insight, knowledge and information shared with ArtMan Delta to make these parts into what they are. ArtMan Delta would also like to thank any unreferenced photographers for their incredible photographs that have assisted in giving the level of detail ArtMan Delta wishes to share with the world for the benefit of historical remembrance and accurate facts but most importantly the joys of modelling. Should any of the photographers recognise photographs in these instruction sheets, please contact ArtMan Delta in order for us to give credit where credit is due. Lastly, thank you, to you, our customer for purchasing an ArtMan Delta set, without your support none of this would be possible.