



ARTMAN
DELTA

A passion for accuracy and detail

Dassault Mirage F1 Underwing Tanks and Wing Pylons

Building Instructions and Colour Callouts

Colour Callouts:

Check reference sources for preferred colours.

The Mirage F1 pylons had many variations of colour with many of them remaining in Natural Metal but were at times painted in various camouflage colours and patterns.

For in depth research, information and photos, see the **ArtMan Delta Info Packs and Reference e-Books** for the **Dassault Mirage F1**

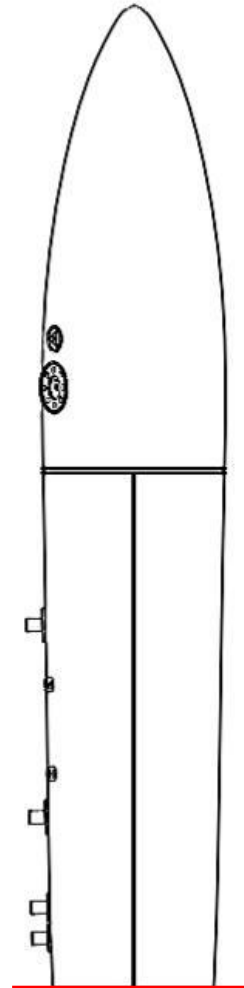

x2

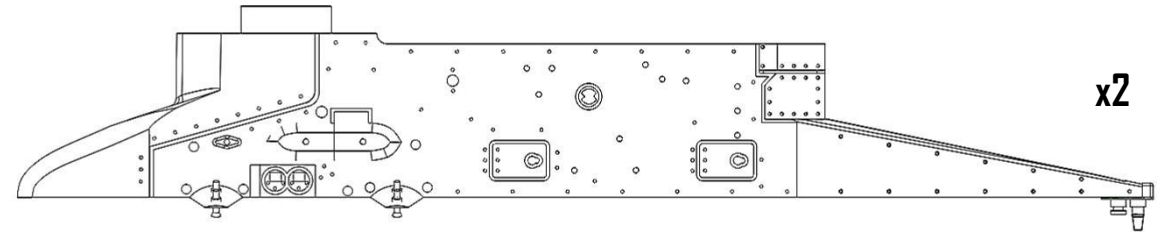

x2

Remove supports from the topside of each pylon

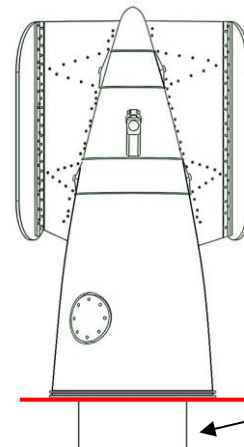

Do not remove locator cylinder

x2

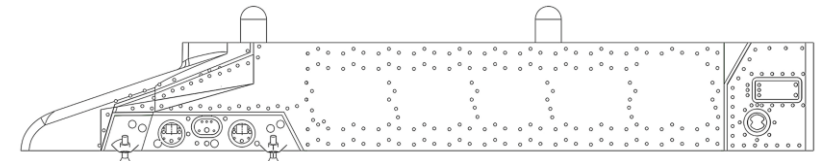

Remove the print supports below the red lines



AD48024 – Designed to be used on Italeri/ESCI 1:48 Dassault Mirage F1 Kits

Use cyanoacrylate glue to bond the parts together

CLB-30 pylons are designed to fit ArtMan Delta Matra LRF-4's, Mk81 and Mk82 Bombs and ELT-555's

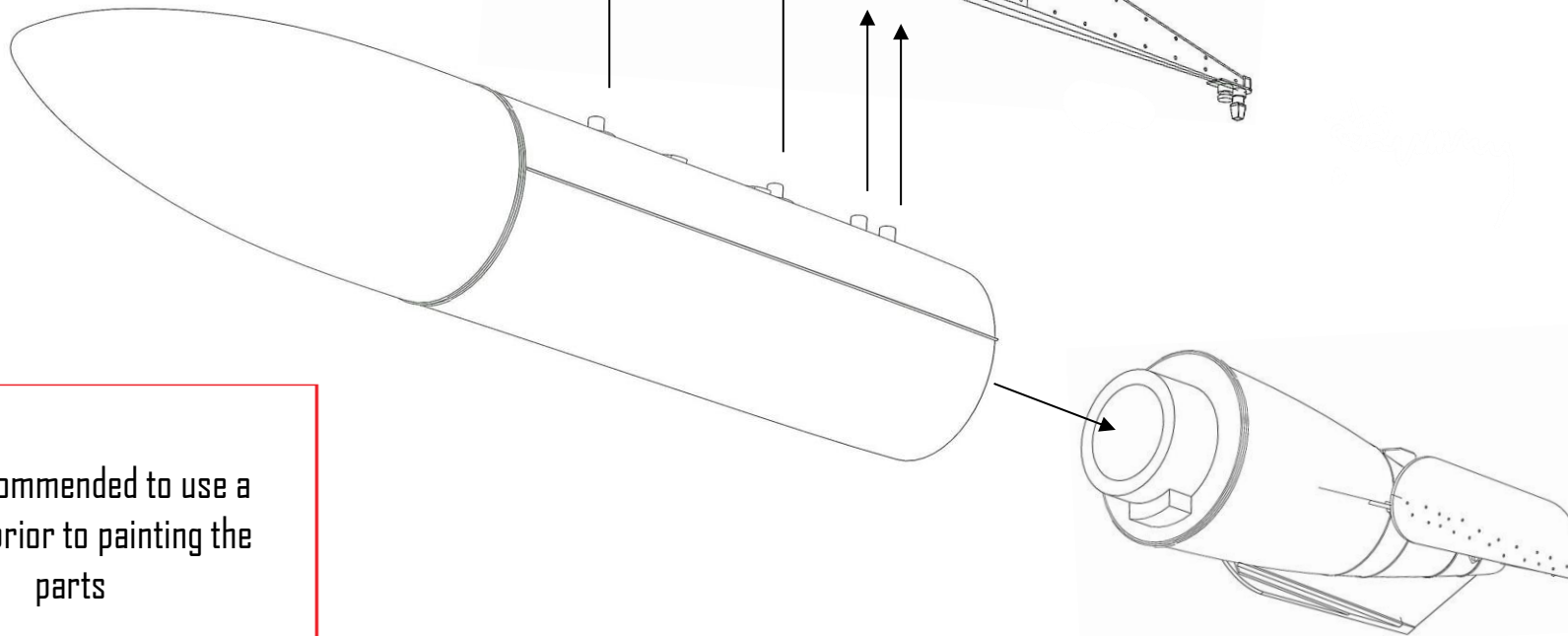
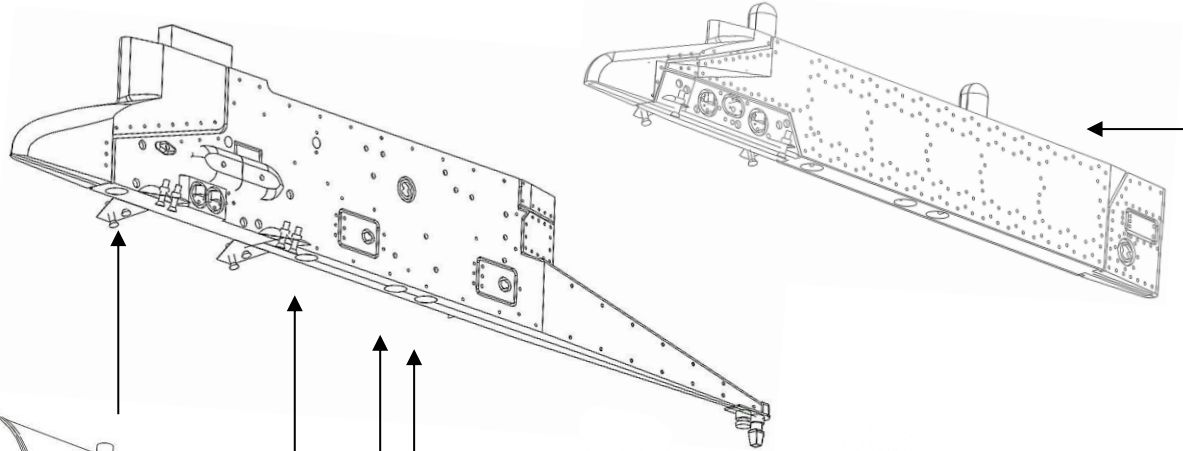

*It is recommended to use a primer prior to painting the parts

- WARNING**
- This is not a toy.
 - These items are not suitable for children.
 - Modelling experience is required.
 - Always wear eye protection when cutting the resin off any supports.
 - Do not breathe the resin dust in as it may be harmful to your health.
 - It is recommended to wear breathing protection such as a face mask when handling and cutting/ grinding/ sanding resin.
 - Not for consumption, keep away from children and animals.